

Rovanco PVC Containment with Quick Fit Fittings

For Above or Below Ground Applications

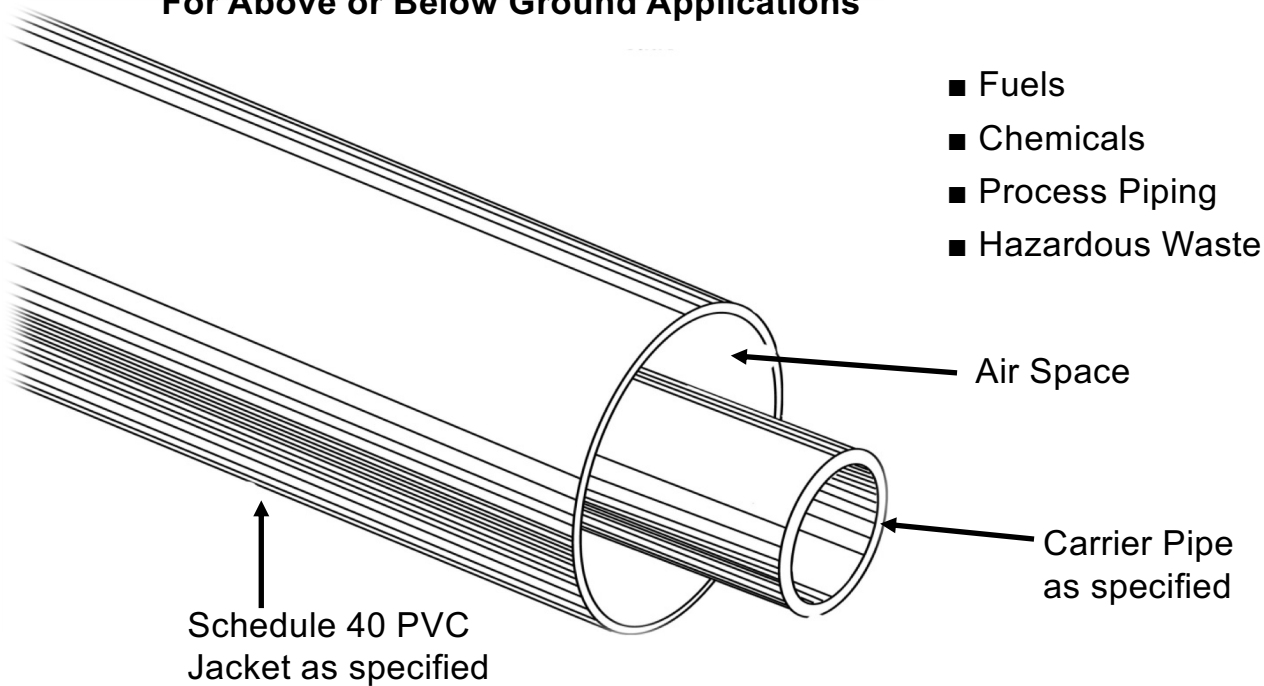

Rovanco's Containment PVC Quick Fit System is designed for piping systems above or below ground. A High-quality, durable PVC jacket, provides an economical system.

Rovanco's Containment PVC Quick Fit System is provided in two ways;

1.) Spooled out, part numbered, cut-to-length pieces factory fabricated to field dimensions. All containment elbows, tees, and end seals are manufactured at Rovanco's plant.

2.) In many cases the Containment pipe can be supplied as a Quick Fit System with 20' or 40' lengths of pipe and field fabricated Quick Fit fittings, end seals, and accessories.

Both Containment Pipe Systems come complete with field joint kits the same thickness as the jacket to make it completely watertight. The right product for tough applications

To find out more about Rovanco's Containment PVC Quick Fit Containment system, you can visit our factory, phone us (815) 741-6700, fax us (815) 741-4229, visit our website at www.rovanco.com or e-mail us at marketing@rovanco.com.

SPECIFICATION DATA SHEET

PVC Quick Fit Containment Piping Systems for Underground

Carrier Pipe Types:

PVC

Schedule 40/80 solvent weld.

Copper Type (K) or (L)

Hard Drawn Copper Tubing conforming to ASTM B-88.

Steel

A-53 Grade B ERW or seamless Steel in Schedule (40) or (80) or Stainless Steel.

Fiberglass

Series 3000 Bondstrand* filament wound fiberglass reinforced epoxy, bell and spigot, designed to withstand 210°F. Pipe to be in conformance with MIL-SPEC P29206A.

High Density Polyethylene

SDR11 – SDR17 and other specialty plastics including, Pex, Polypropylene, and CPVC.

Other carrier pipe types are available upon request.

Factory fabricated and pre-engineered to actual field dimensions.

Inner Pipe Supports:

All pipe shall be aligned and supported within the casing with galvanized steel supports spaced on centers approximately 10'0". The insulated inner pipe shall bear directly on the steel support. The support shall be designed as to permit drainage and free air passage. All pipe passing through supports shall be insulated. Concrete type pipe supports will not be allowed.

Outer Containment Casing:

The outer casing shall be Schedule 40 PVC conforming to ASTM 1785. Fiberglass casing will not be allowed.

Coupling Joints:

The Quick Fit Joint is made of three parts; the coupling unit and two identical sealing rings (field assembled).

Fittings:

Fittings shall be factory pre-fabricated and the containment pipe fittings will be made of PVC, the same thickness as the containment casing for the factory fabricated spooled out systems, or with factory supplied field assembled Quick Fit fittings and couplings.

End Seal:

Terminal ends of system shall be equipped with Quick Fit end seals manufactured of PVC or other non-corrosive materials and factory tested..

Casing, Fittings, and End Seal Testing and Certification:

Testing and certification procedures shall demonstrate that the casing, fittings, and end seals are capable of passing a pressure test certified by an independent testing agency.

Installation:

The installation shall be done in accordance with plans and specifications and manufacturer's installation drawings and instructions. The containment pipe manufacturer can provide a field service technician on-site to train the contractor and his personnel in all phases of installation if no contractor or field fabricated systems will be allowed.

Backfill:

Should be tampered compactly in place so as to assure a stable surface. No rock shall be used in the first foot of backfill. 24 inches, top of pipe to grade, of compacted fill shall meet H-20 Highway loading.

Approved Supplier:

Quick Fit PVC Containment Pipe System manufactured by Rovanco, Joliet, Illinois, 815-741-6700, or approved, ISO certified, equal. Any alternative supplier must submit their technical data to the engineer ten days prior to bid date to be approved in writing as an equal.

cc #06152023

Copyright 2023 – Rovanco's products are covered by various U.S. patents. Rovanco & Insul-8 are federally registered trademarks.

Contact Rovanco® for the name of your local Representative

20535 S.E. Frontage Road • Joliet, Illinois 60431 • (815) 741-6700

Website: www.rovanco.com • E-mail: marketing@rovanco.com

This is a generic product datasheet and is not intended for submittal use.